

Armstrong METALWORKS

Perforation Designs for Steel Panels

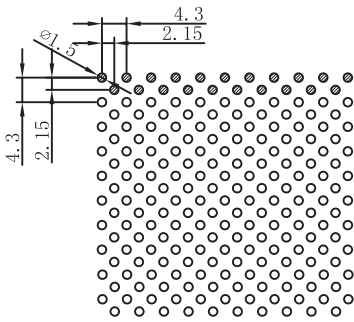

No. P17 | Max. width 705.2mm
Thickness 0.5mm
Open Area 19.1%

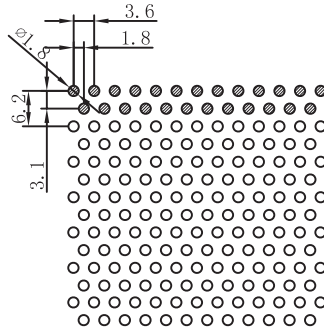

No. P20 | Max. width 702mm
Thickness 0.5mm
Open Area 22.8%

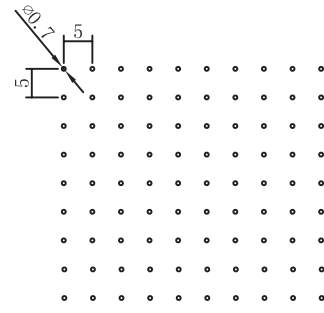

No. P21 | Max. width 690mm
Thickness 0.5mm
Open Area 1.54%

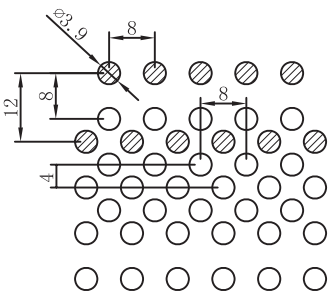

No. P22 | Max. width 712mm
Thickness 0.7mm
Open Area 37.3%

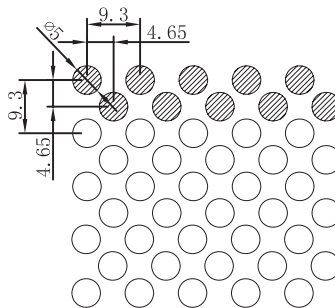

No. P25 | Max. width 576.6mm
Thickness 0.5-0.7mm
Open Area 45.38%

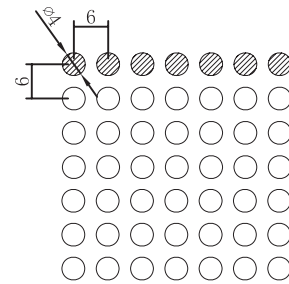

No. P26 | Max. width 726mm
Thickness 0.4-0.7mm
Open Area 34.9%

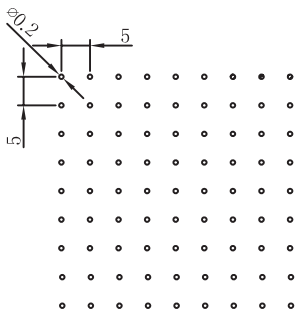

No. P28 | Max. width 750mm
Thickness 0.5mm
Open Area 2.0%

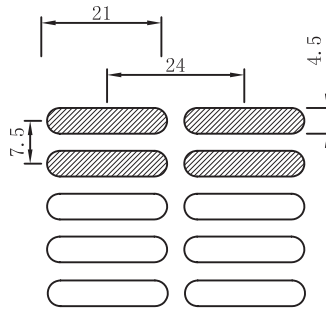

No. P29 | Max. width 1053mm
Thickness 0.7mm
Open Area 50%

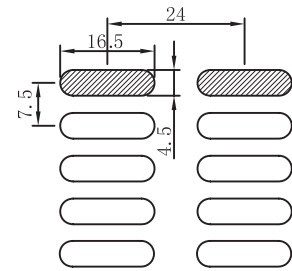

No. P29a | Max. width 300mm
Thickness 0.87mm
Open Area 38.8%

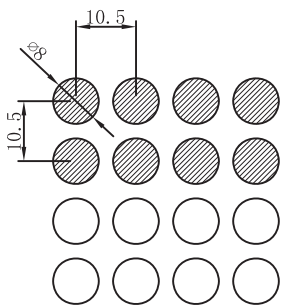

No. P31 | Max. width 1050mm
Thickness 0.5-0.8mm
Open Area 45.6%

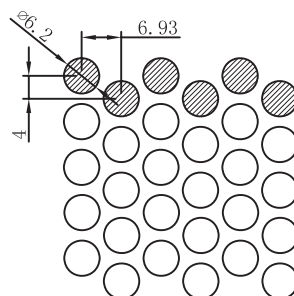

No. P32 | Max. width 714mm
Thickness 0.7-0.8mm
Open Area 54.44%

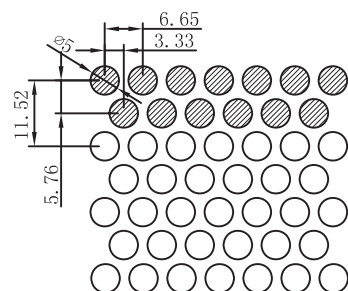

No. P33 | Max. width 705mm
Thickness 0.7-0.8mm
Open Area 51.3%

Postal address: Armstrong Ceiling Division Head Office: 99 Derby Street, Silverwater NSW 2128 Australia

Customer Service: Sydney New South Wales: (612) 9748 1588 Melbourne Victoria: (613) 9580 9633 Brisbane Queensland (617) 3809 5565

Armstrong METALWORKS Perforation Designs for Steel Panels

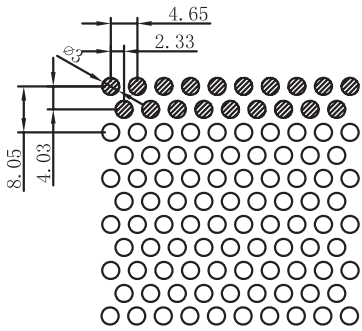

No. P34 | Max. width 706.8mm
Thickness 0.7~0.8mm
Open Area 37.8%

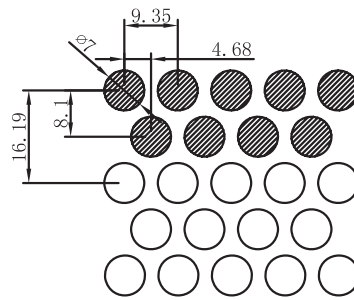

No. P35 | Max. width 710.6mm
Thickness 0.7~0.8mm
Open Area 50.8%

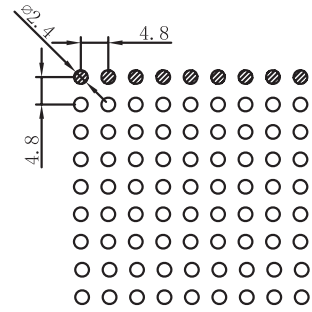

No. P38 | Max. width 864mm
Thickness 0.7~0.8mm
Open Area 19.6%

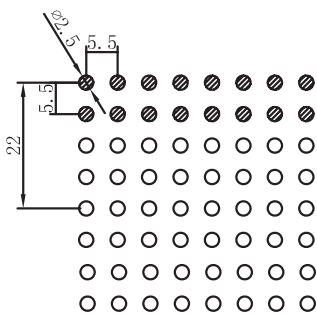

No. P39 | Max. width 1138.5mm
Thickness 0.5~1.0mm
Open Area 16.2%

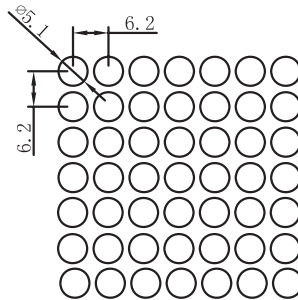

No. P41 | Max. width 624mm
Thickness 0.5~0.8mm
Open Area 46.5%

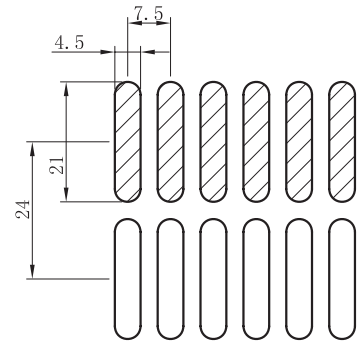

No. P44 | Max. width 1027.5mm
Thickness 0.7mm
Open Area 50%

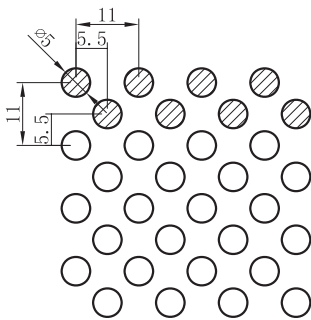

No. P45 | Max. width 275mm
Thickness 0.7mm
Open Area 30%

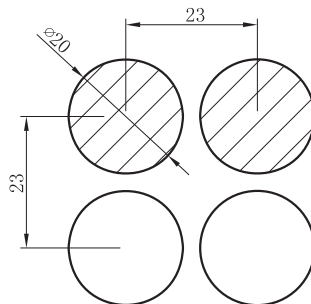

No. P46 | Max. width 988mm
Thickness 0.7mm
Open Area 52.9%

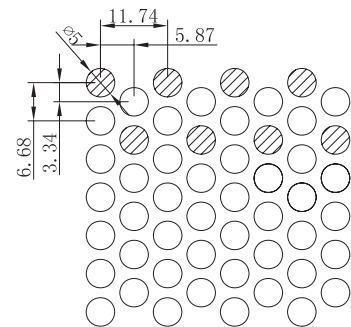

No. P47 | Max. width 821.8mm
Thickness 0.7mm
Open Area 45.6%

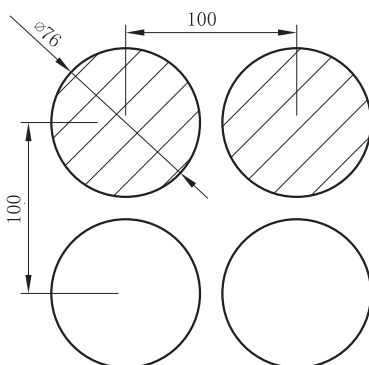

No. P48 | Max. width 600mm
Thickness 0.7mm
Open Area 45%

